

## Miniature Relay for Signal Circuits

- ROHS compliant.
- Wide switching power of 10  $\mu$ A to 2 A.
- High dielectric strength coil-contacts: 1,000 VAC; open contacts: 750 VAC.
- Conforms to FCC Part 68 requirements.
- Ag (Au alloy) bifurcated crossbar contacts and fully sealed for high contact reliability.
- New 150-mW relays with high-sensitivity.



## Ordering Information

Classification	Contact form	Contact type	Contact material	Enclosure Rating	Model
Standard	DPDT	Bifurcated crossbar	Ag (Au alloy)	Fully sealed	G5V-2
High-sensitivity					G5V-2-H1

**Note:** When ordering, add the rated coil voltage to the model number.

Example: G5NB-1A-E 12 VDC

Rated coil voltage

### Model Number Legend

G5V -    -       VDC  
           1   2   3

1. Contact Form  
 2: DPDT

2. Classification  
 H1: High-sensitivity

3. Rated Coil Voltage  
 3, 5, 6, 9, 12, 24, 48 VDC

## Specifications

### ■ Coil Rating

#### Standard Models

Rated voltage	3 VDC	5 VDC	6 VDC	9 VDC	12 VDC	24 VDC	48 VDC
Rated current	166.7 mA	100 mA	83.3 mA	55.6 mA	41.7 mA	20.8 mA	12 mA
Coil resistance (W)	18 $\Omega$	50 $\Omega$	72 $\Omega$	162 $\Omega$	288 $\Omega$	1,152 $\Omega$	4,000 $\Omega$
Coil inductance (H) (ref. value)	Armature OFF	0.04	0.09	0.16	0.31	0.47	1.98
	Armature ON	0.05	0.11	0.19	0.49	0.74	2.63
Must operate voltage	75% max. of rated voltage						
Must release voltage	5% min. of rated voltage						
Max. voltage	120% of rated voltage at 23°C						
Power consumption	Approx. 500 mW						Approx. 580 mW

## High Sensitivity Models

<b>Rated voltage</b>	3 VDC	5 VDC	6 VDC	9 VDC	12 VDC	24 VDC	48 VDC
<b>Rated current</b>	50 mA	30 mA	25 mA	16.7 mA	12.5 mA	8.33 mA	6.25 mA
<b>Coil resistance</b>	60 Ω	166.7 Ω	240 Ω	540 Ω	960 Ω	2,880 Ω	7,680 Ω
<b>Coil inductance</b>	<b>Armature OFF</b>	0.18	0.46	0.70	1.67	2.90	6.72
<b>(H) (ref. value)</b>	<b>Armature OFF</b>	0.57	0.71	0.97	2.33	3.99	26.7
<b>Must operate voltage</b>	75% max. of rated voltage						
<b>Must release voltage</b>	5% min. of rated voltage						
<b>Max. voltage</b>	180% of rated voltage at 23°C						150% of rated voltage (at 23°C)
<b>Power consumption</b>	Approx. 150 mW					Approx. 200 mW	Approx. 580 mW

- Note:**
1. The rated current and coil resistance are measured at a coil temperature of 23°C with a tolerance of ±10%.
  2. Operating characteristics are measured at a coil temperature of 23°C.
  3. The maximum voltage is the highest voltage that can be imposed on the relay coil.

## ■ Contact Ratings

Item	Standard models	High sensitivity models
<b>Load</b>	Resistive load ( $\cos\varphi = 1$ )	
<b>Rated load</b>	0.5 A at 125 VAC; 2 A at 30 VDC	0.5 A at 125 VAC; 1 A at 24 VDC
<b>Contact material</b>	Ag (AU alloy)	
<b>Rated carry current</b>	2 A	
<b>Max. switching voltage</b>	125 VAC, 125 VDC	
<b>Max. switching current</b>	2 A	1 A
<b>Max. switching power</b>	62.5 VA, 60 W	62.5 VA, 24 W
<b>Failure rate (reference value)</b>	0.01 mA at 10 mVDC	

**Note:** P level:  $\lambda_{60} = 0.1 \times 10^{-6}$ /operation

This value was measured at a switching frequency of 120 operations/min and the criterion of contact resistance is 100Ω. This value may vary depending on the switching frequency and operating environment. Always double-check relay suitability under actual operating conditions.

## ■ Characteristics

Item	Standard models	High sensitivity models
<b>Contact resistance (see note 1)</b>	50 mΩ max.	100 mΩ max.
<b>Operate time</b>	7 ms max.	
<b>Release time</b>	3 ms max.	
<b>Max. operating frequency</b>	Mechanical: 36,000 operations/hr Electrical: 1,800 operations/hr (under rated load)	
<b>Insulation resistance (see note 2)</b>	1,000 MΩ min. (at 500 VDC)	
<b>Dielectric strength</b>	1,000 VAC, 50/60 Hz for 1 min between coil and contacts 1,000 VAC, 50/60 Hz for 1 min between contacts of different polarity 750 VAC, 50/60 Hz for 1 min between contacts of same polarity	1,000 VAC, 50/60 Hz for 1 min between coil and contacts 1,000 VAC, 50/60 Hz for 1 min between contacts of different polarity 500 VAC, 50/60 Hz for 1 min between contacts of same polarity
<b>Impulse withstand voltage</b>	1,00 V (10 x 160 μs) between coil and contacts (conforms to FCC part 68)	
<b>Vibration resistance</b>	Destruction: 10 to 55 to 10 Hz, 0.75-mm single amplitude (1.5-mm double amplitude) Malfunction: 10 to 55 to 10 Hz, 0.75-mm single amplitude (1.5-mm double amplitude)	
<b>Shock resistance</b>	Destruction: 1,000 m/s <sup>2</sup> (approx. 100G) Malfunction: 200 m/s <sup>2</sup> (approx. 20G)	Destruction: 1,000 m/s <sup>2</sup> (approx. 100G) Malfunction: 100 m/s <sup>2</sup> (approx. 10G)
<b>Endurance</b>	Mechanical: 15,000,000 operations min. (at 36,000 operations/hr) Electrical: 100,000 operations min. (at 1,800 operations/hr)	
<b>Ambient temperature</b>	Operating: -25°C to 65°C (with no icing)	Operating: -25°C to 70°C (with no icing)
<b>Ambient humidity</b>	Operating: 5% to 85%	
<b>Weight</b>	Approx. 5 g	

**Note:** The above values are initial values.

1. The contact resistance was measured with 10mA at 1VDC with a voltage drop method.
2. The insulation resistance was measured with a 500VDC megohmmeter applied to the same parts as those used for checking the dielectric strength.

## ■ Approved Standards

**UL (File No. E41515)/CSA C22.2 No.0,  
No.14 (File No. LR24825)**

Contact form	Coil rating	Contact rating	
		G5V-2	G5V-2-H1
DPDT	3 to 48 VDC	0.6 A, 125 VAC (general use) 0.6 A, 110 VDC (resistive load) 2 A, 30 VDC (resistive load)	0.5 A, 125 VAC (general use) 0.2 A, 110 VDC (resistive load) 1 A, 24 VDC (resistive load)

Engineering Data

Maximum Switching Power  
G5V-2

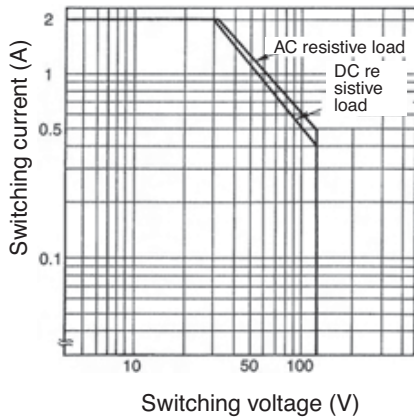

Endurance  
G5V-2

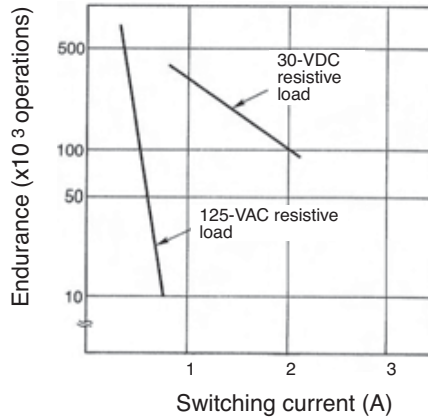

Ambient Temperature vs.  
Maximum Coil Voltage  
G5V-2

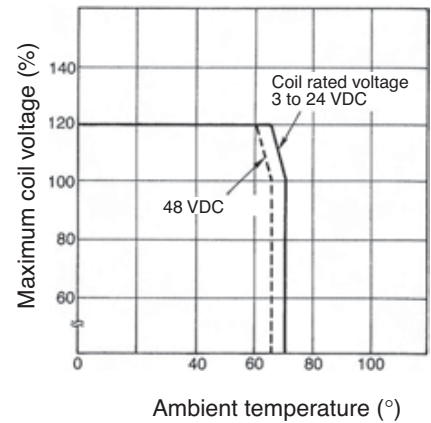

**Note:** The maximum coil voltage refers to the maximum value in a varying range of operating power voltage, not a continuous voltage.

G5V-2-H1

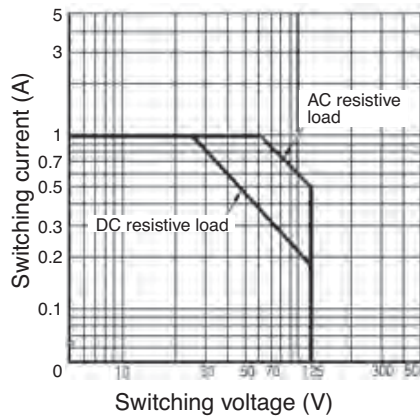

G5V-2-H1

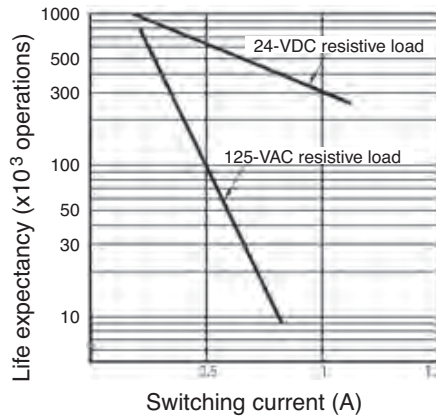

G5V-2-H1

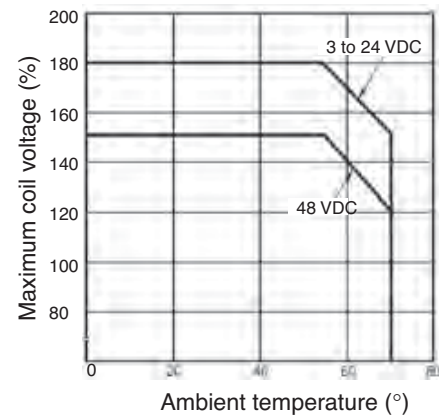

**Note:** The maximum coil voltage refers to the maximum value in a varying range of operating power voltage, not a continuous voltage.

## Dimensions

**Note:** 1. All units are in millimetres unless otherwise indicated.

2. Orientation marks are indicated as follows:  

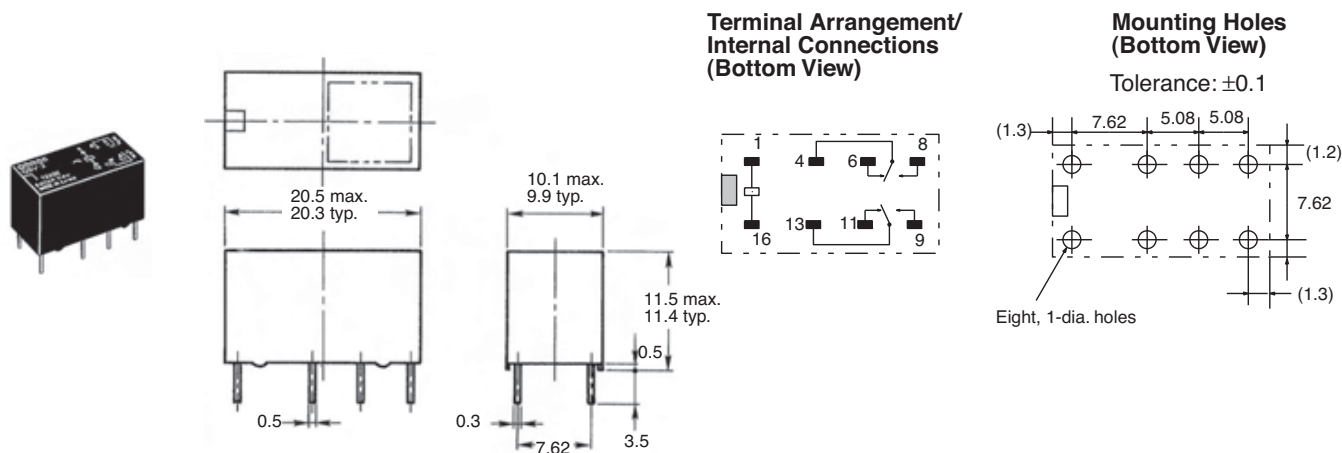

## Precautions

### Long-term Continuously ON Contacts

Using the Relay in a circuit where the Relay will be ON continuously for long periods (without switching) can lead to unstable contacts because the heat generated by the coil itself will affect the insulation, causing a film to develop on the contact surfaces. Be sure to use a fail-safe circuit design that provides protection against contact failure or coil burnout.

### Relay Handling

When washing the product after soldering the Relay to a PCB, use a water-based solvent or alcohol-based solvent, and keep the solvent temperature to less than 40°C. Do not put the Relay in a cold cleaning bath immediately after soldering.